





ASG 5 2020



30%
less
production
costs

Your efficiency is our benchmark.

-  Intelligent and complete face automation
-  Control of the longwall from each support
-  Maximum efficiency of coal extraction
-  Longest service life

Real Time
Automation

Key component
of the TCS face
automation

Key component of the TCS face automation

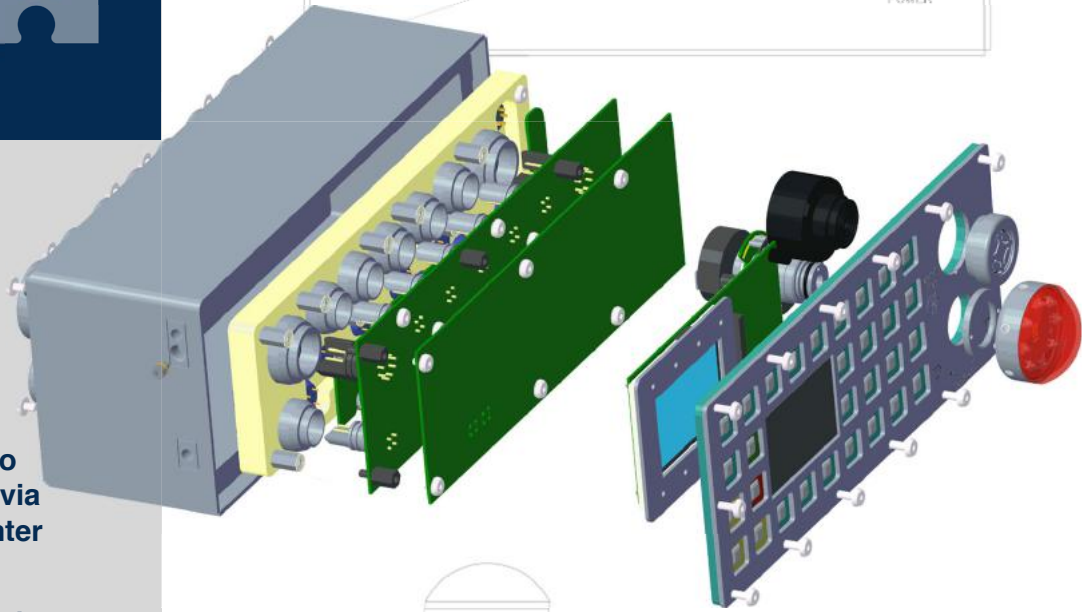
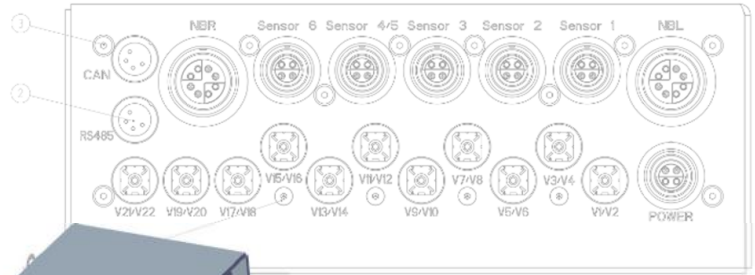
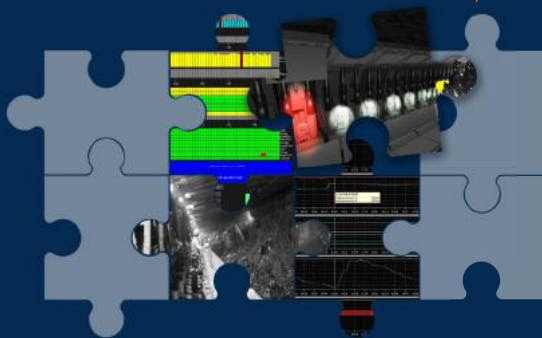

- > Automation beyond the ends of the longwall
- > 3D visualisation of the complete face
- > Remote control with radio control unit, IS-Tablet or via the remote operation center

- > Individual keyboard layouts including programmable softkeys

- > Caption of the complete shield geometry by inclinometers

- > Facewide status overview directly on the device

- > Integrated and automated lifecycle management of connected components

- > Multiple communication systems

- > Latest interface technologies for extensions

- > High data rate of the face communication (comparable to Ethernet)

- > Approvals: ATEX, IECEx, MA, EAC, MSHA, BAS

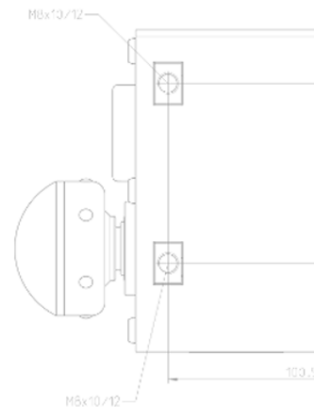
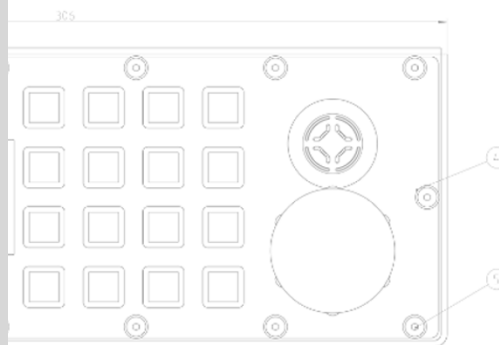
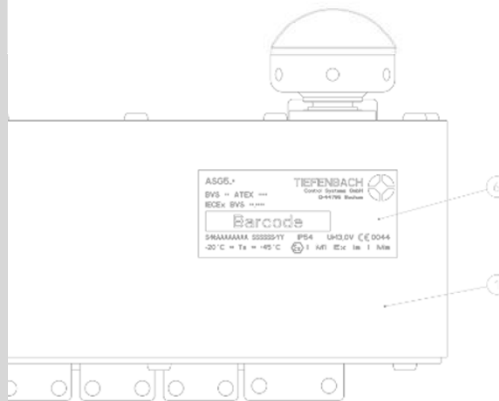



tibacon.com

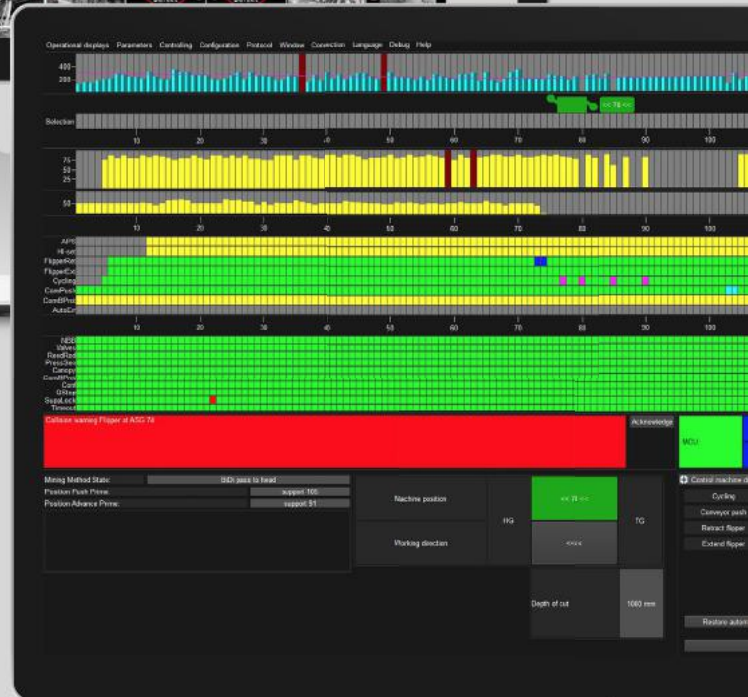
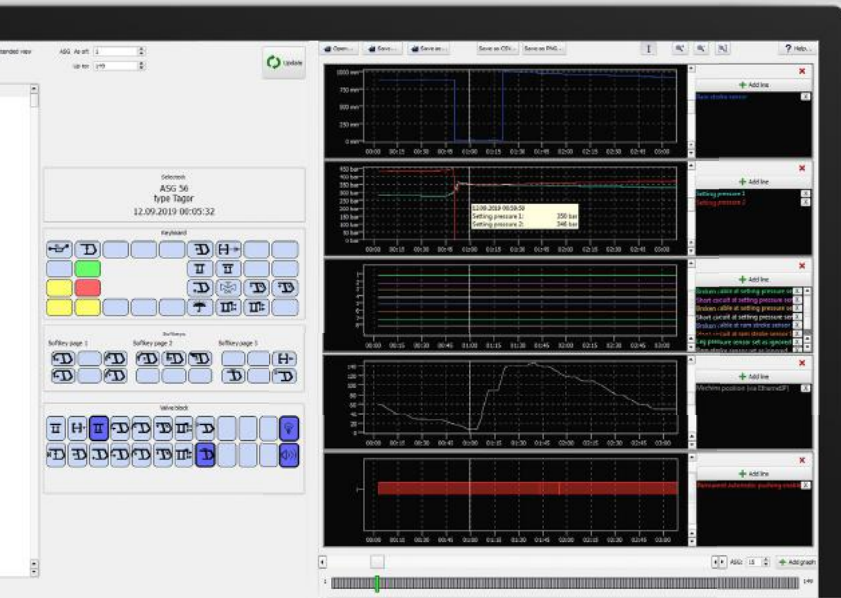

Tiefenbach Control Systems GmbH
Rombacher Hütte 18a
44795 Bochum

Phone: +49 (0) 234 - 77766-0
Fax: +49 (0) 234 - 77766-999
info@tibacon.com

TIEFENBACH
Control Systems GmbH

